

# UL1008 - EMERGENCY LIGHTING TRANSFER CABINET

Series B6700 for 277V circuits with Type 3 Emergency feed

## FEATURES

- ◆ Allows dimmable lighting fixtures to function as essential emergency lighting
- ◆ Continuously monitors normal and emergency power
- ◆ Automatically transfers essential loads from normal power to emergency power
- ◆ NEMA 4, watertight enclosures are standard
- ◆ Compact design saves space
- ◆ Up to 32 20A circuits (64 poles) per cabinet

## APPLICATIONS

- ◆ Restaurants, Theatres and Auditoriums
- ◆ Ballrooms, Casinos and Exhibition Halls
- ◆ Hotels, Conference Centers and Sports Facilities

## CODES

- ◆ UL 1008 Listed and Labeled
- ◆ Complies with NFPA 110, Emergency & Standby Power Systems
- ◆ Meets NEC requirements outlined in:
  - Article 701—Legally Required Standby Systems
  - Article 700—Emergency Systems
  - Article 540-11c—Motion Picture Houses
  - Article 520-7—Theatres & Similar Locations and
  - Article 518-3c—Places of Public Assembly

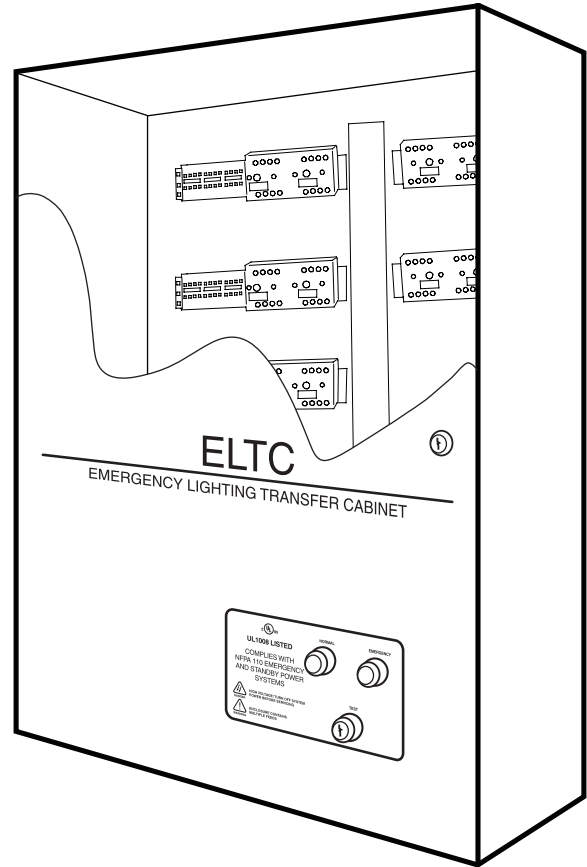

## TYPE 3 EMERGENCY FEED

The Type 3 emergency power feed to the transfer cabinet consists of a single 3PH, 4 wire + ground 277/480VAC circuit. Emergency power lands on input lugs in the bottom of the cabinet. Internal wiring with branch circuit breakers distributes the emergency power to the transfer relays.

## OPTIONS

- ◆ Three pole breaker to protect wiring for sensing feed
- ◆ Remote Key Station with indicator lights
- ◆ Configuration to transfer 3 wire dimmed fluorescent fixtures

## APPROVAL

Job name \_\_\_\_\_

Job number \_\_\_\_\_

Location \_\_\_\_\_

Date \_\_\_\_\_

Approved by \_\_\_\_\_

MODEL	EMERGENCY CIRCUITS	ENCLOSURE SIZE	WEIGHT
B670002-3	2 x 20A	24" x 24" x 8"	86
B670004-3	4 x 20A	36" x 24" x 8"	132
B670006-3	6 x 20A	36" x 24" x 8"	137
B670008-3	8 x 20A	36" x 24" x 8"	142
B670010-3	10 x 20A	36" x 24" x 8"	147
B670012-3	12 x 20A	36" x 24" x 8"	152
B670014-3	14 x 20A	48" x 36" x 8"	296
B670016-3	16 x 20A	48" x 36" x 10"	301
B670018-3	18 x 20A	48" x 36" x 10"	306
B670020-3	20 x 20A	48" x 36" x 10"	311
B670022-3	22 x 20A	60" x 36" x 10"	355
B670024-3	24 x 20A	60" x 36" x 10"	360
B670026-3	26 x 20A	60" x 36" x 10"	365
B670028-3	28 x 20A	60" x 36" x 10"	370
B670030-3	30 x 20A	60" x 36" x 10"	375
B670032-3	32 x 20A	60" x 36" x 10"	380



# UL1008 - EMERGENCY LIGHTING TRANSFER CABINET

## Series B6700 for 277V circuits with Type 3 Emergency feed

### SPECIFICATIONS

- The Emergency Lighting Transfer Cabinet shall provide automatic transfer of the line and neutral conductors of each branch circuit from normal to emergency power when normal power fails. The cabinet shall automatically reconnect circuits to normal power when normal power has been restored.
- The transfer cabinet contacts shall be electrically operated and mechanically held. The entire assembly shall be UL1008 listed and labeled. This equipment must comply with the regulations in NFPA 110 for Emergency and Standby Power Systems.
- The Emergency Lighting Transfer Cabinet must also satisfy the requirements of NFPA 70 (National Electrical Code).
  - Article 701—Legally Required Standby Systems
  - Article 700—Emergency Systems
  - Article 540-11c—Motion Picture Houses
  - Article 520-7, Theatres and Similar Locations
  - Article 518-3c—Places of Public Assembly
- The Emergency Lighting Transfer Cabinet shall be a wall-mounted, NEMA 4 enclosure constructed of 14-gauge steel finished in matte black powder coat paint. All terminations and wiring shall be accessible via a hinged lockable door. The cabinet shall be pre-wired and tested at the factory with clearly marked terminals for contractor wiring of normal feed, emergency feed, lighting loads and sensing feeds.
- Standard transfer relays shall be available at 20A and 50A current ratings.
- The Emergency Lighting Transfer Cabinet shall accommodate circuits of two wire, dimmed incandescent or fluorescent lighting as well as three wire, dimmed, fluorescent lighting.
- Emergency Lighting Transfer Cabinets with Type 3 emergency power feeds shall provide for power distribution and branch circuit protection internally for all emergency power circuits.
- The front panel of the Emergency Lighting Transfer Cabinet shall contain a key-switch to simulate power failure for testing purposes as well as indicator lights to visually signal the presence of normal or emergency power.
- Voltage sensing of the Normal source shall cause automatic transfer when the voltage of one or more phases drops below 55% of 120VAC.
- Factory default settings for time delay of transfer are as follows: Normal to Emergency—0 Seconds, Emergency back to Normal 3 seconds. These settings shall be field adjustable.
- Provisions for optional remote signal, fire alarm and other input signals shall be incorporated into the control circuit.
- Provide Emergency Lighting Transfer Cabinets as manufactured by Stagecraft Industries, Inc. or approved equal.

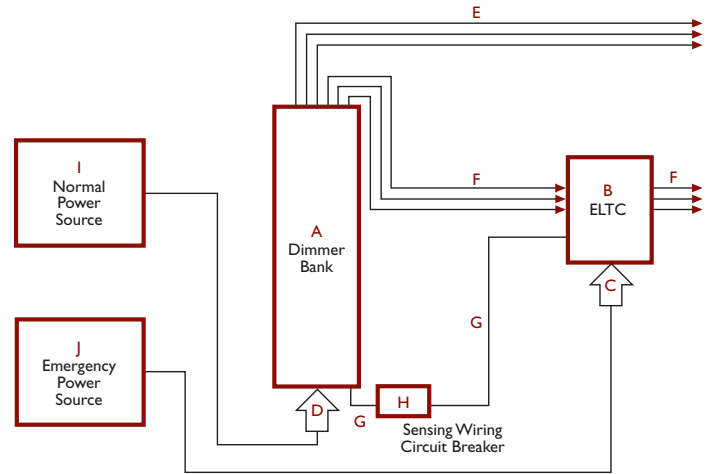

- DIMMER BANK**—All lighting circuits are controlled through the dimmer bank using standard stage lighting or architectural controls. When normal power is present, circuits designated as “emergency circuits” respond to the same controls as the non-emergency circuits.
- EMERGENCY LIGHTING TRANSFER CABINET (ELTC)**—The dimmed lighting circuits which serve as emergency lighting are routed through a UL1008 ELTC which continuously monitors the input power to the dimmer bank. If any phase of the three phase input power to the dimmer bank falls below 55% of normal, the ELTC transfers both the hot and the neutral conductors of each circuit to the emergency power source. This automatically energizes the emergency lighting fixtures.
- TYPE 3 EMERGENCY INPUT POWER**—The Type 3 emergency power feed to the transfer cabinet consists of a single 3PH, 4 wire + ground 277/480VAC circuit. Emergency power lands on input lugs in the bottom of the cabinet. Internal wiring with branch circuit breakers distributes the emergency power to the transfer relays.
- NORMAL POWER FEED TO DIMMER RACK**—A three phase, 4 wire + ground feed from the normal building power (I) provides power to the dimmer bank.
- LIGHTING CIRCUITS**—Dimmed lighting circuits designated for emergency use (F) can be dimmed normally but transfer to emergency source (J) if power to the dimmer bank fails. Dimmed lighting circuits that are not a part of the emergency lighting (E) are connected directly to the dimmer bank.
- SENSING FEED**—The ELTC monitors normal power to the dimmer bank through a 277/480V, three phase, four-wire sensing feed of #12AWG wire. Sensing feed wiring must be protected either by an over-current device provided by the dimmer manufacturer in the dimmer bank or by adding an external three pole breaker between the dimmer and the ELTC.
- SENSING WIRING CIRCUIT BREAKERS**—To protect the sensing feed wiring between the dimmer and the ELTC; a three-pole 15A breaker may be mounted adjacent to the dimmer bank. This breaker and enclosure are not provided with the ELTC, but may be added as an option.
- NORMAL POWER SOURCE**—Normal building power, typically from the public utility.
- EMERGENCY POWER SOURCE**—From a generator, an inverter or even from a secondary utility feed.